

THIS DRAWING IS UNPUBLISHED. RELEASED FOR PUBLICATION, 19
 © COPYRIGHT 19 BY AMP INCORPORATED. ALL INTERNATIONAL RIGHTS RESERVED.

LOC	DIST	P	F	ZONE	LTR	DESCRIPTION	DATE	APPD
AF	50				E	ADDED -5 PER OG3A-0200-00	15MAR00	JR/DB

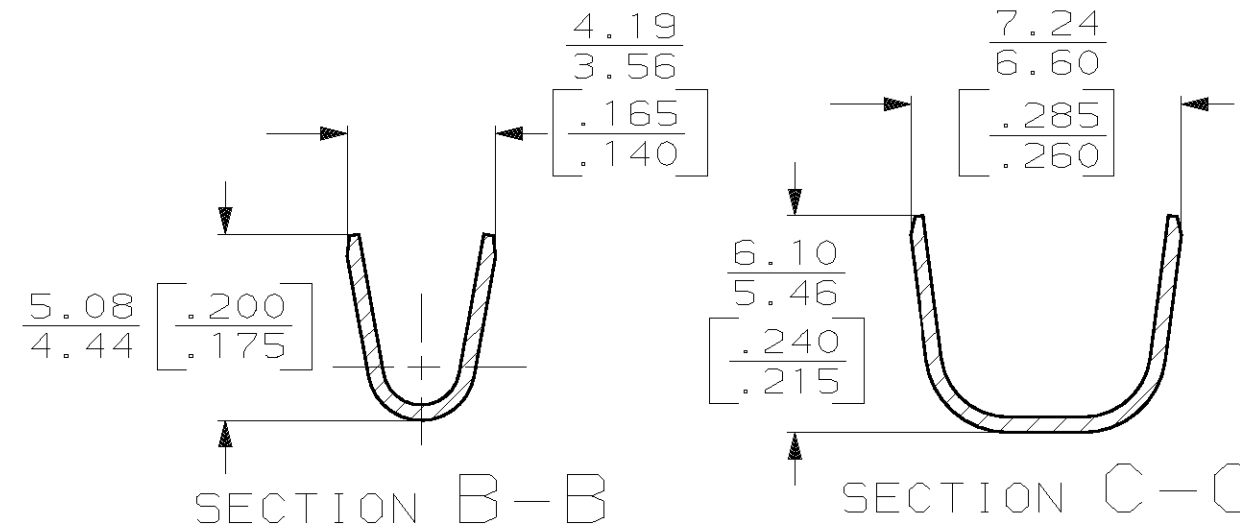
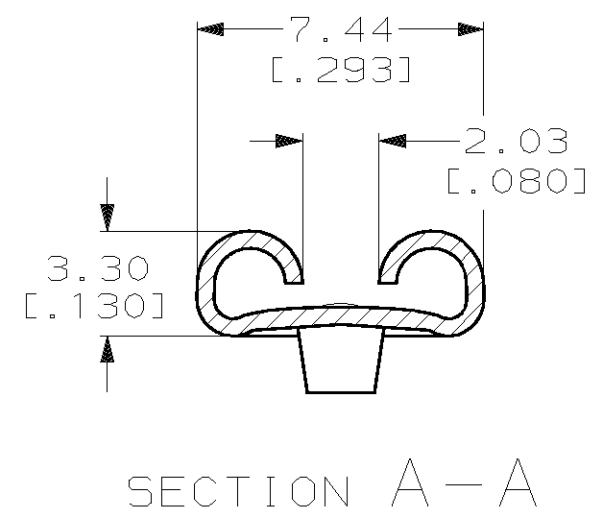
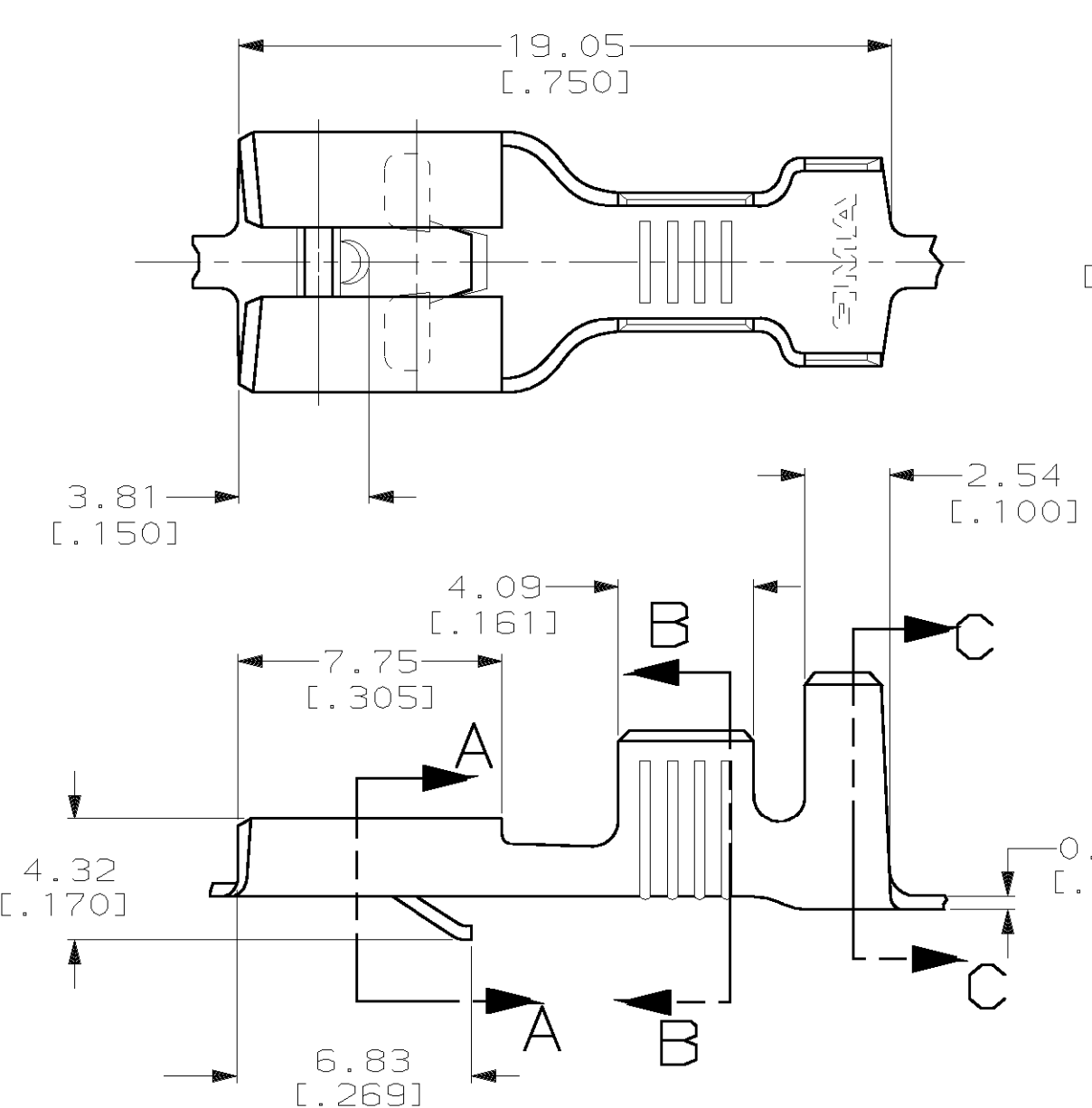

- 1 CONTINUOUS STRIP ON REELS.
- 2 ACCEPTS WIRE SIZE [#16-#12 OR TWO #16'S].
- 3 INSULATION RANGE TO BE 4.06-5.33 [.160-.210] OR TWO 3.30 [.130] MAX DIA.
- 4 MATING TAB THK IS 0.81±0.025 [.032±.001].
- △5 INTERLEAVING PAPER REQUIRED.
- △6 PRELIMINARY - NOT FOR PRODUCTION

FINISH	PART NO
△5 0.002032 [.000080] MIN TIN	△6 60249-5
0.000381 [.000015] THK SILVER	60249-3
0.002032 [.000080] MIN TIN	60249-2
-	60249-1

THIS DRAWING IS A CONTROLLED DOCUMENT FOR AMP INCORPORATED. IT IS SUBJECT TO CHANGE AND THE CONTROLLING ENGINEERING ORGANIZATION SHOULD BE CONTACTED FOR THE LATEST REVISION.

DO NOT SCALE PRINT. UNLESS SPECIFIED DIMENSIONS IN mm [INCHES] TOLERANCES ON: 2 PLC DEC ± 0.38 [.015] 3 PLC DEC ± - ANGLES ± -	DR 7/14/95 JR RUTH CHK 7/14/95 MS FEHER APPD 7/14/95 J GILLESPIE APPD 7/14/95 R REINER	AMP Incorporated Harrisburg, PA 17105-3608
MATERIAL H04 BRASS	PRODUCT SPEC -	
FINISH SEE TABLE	APPLICATION SPEC 114-2025 WEIGHT -	NAME RECEPTACLE, FASTIN-FASTON, 6.35 [.250] SERIES
	SIZE B	CAGE CODE 00779
		DRAWING NO C-60249
	SCALE 5:1	SHEET 1 OF 1